



FANTASY BATTLES: THE 9TH AGE TEAM TOURNAMENT

SATURDAY - APRIL 2ND
9:00AM - 7:30PM

Do not lose this packet! It contains all necessary missions and results sheets required for you to participate in today's tournament. It is your responsibility to hold onto and not lose this packet during the tournament. If you lose this packet, be prepared to be docked points!

FANTASY BATTLES: THE 9TH AGE TEAM TOURNAMENT BASIC RULES

- Each Team will consist of two (2) 1000 point contingents.
- Lord level characters are **NOT** allowed.
- The following army list versions are allowed: Beast Herds (v0.11.0), Daemon Legions (v0.11.1), Dread Elves (v0.11.0), Dwarven Holds (v0.11.0), Empire of Sonnstahl (v0.11.1), Highborn Elves (v0.11.0), Infernal Dwarves (v0.12.0), Kingdom of Equitaine (v0.11.0), Ogre Khans (v0.11.0), Orcs and Goblins (v0.11.1), Saurian Ancients (v0.11.0), Sylvan Elves (v0.11.1), The Vermin Swarm (v0.11.0), Undying Dynasties (v0.11.1), Vampire Covenant (v0.11.0), Warriors of the Dark Gods (v0.11.1).
- Each contingent must separately satisfy the rules for Building Your Army as stated in the [Fantasy Battles: 9th Age rulesbook](#). Please use the “Warbands Composition” when creating your Army list (i.e. minimum of three units, max 1 rare choice up to 25%, etc.) except as otherwise described in this rules packet.
- Each contingent must have a General and will consider their partners General as their Battles Standard Bearer (BSB). When determining victory points, only use the “Their King is Dead” victory points condition for destroyed generals.
- As this is a Team Event, players are encouraged to use contingents from two different army books/races. Any alliance is allowed with no in-game penalty but Teams using two armies within the following groups will receive 5 bonus points:
 - Dwarven Holds, Empire of Sonnstahl, Highborn Elves, Kingdom of Equitaine, Saurian Ancients, Sylvan Elves
 - Warriors of the Dark Gods, Infernal Dwarves, Daemon Legions, Dread Elves, Vampire Covenant, Vermin Swarms
 - Ogre Khans, Orcs & Goblins, Undying Dynasties, Beast Herds
- Each Team will be considered a single army for magic items as described in the [Fantasy Battles: 9th Age rulesbook](#).
- Each Team will be considered a single army for spell generation purposes. Please follow the guidelines as stated in the [Fantasy Battles: 9th Age rulesbook](#). We will be using v.0.11.2 paths of magic. If your army contains Wizards, the Path that each wizard chooses **MUST** be declared in their army list.
- This will be an Open List Event. Please provide a copy of your list to your opponents at the beginning of each match.
- All points, stats, and items **MUST** be present on each army list and each unit entry.
- Wood Elves are allowed their free forests, however they must be of the appropriate size (no bigger than 6" in diameter), fully painted and complete with trees (no pieces of paper). A Team consisting of 2 Wood Elf players will only receive one free forest.
- The cut-off date for new Fantasy Battles: 9th Age updates is February 28th, 2016. All updates after said date **WILL NOT** be used for this event.
- Each Team must provide four sets of (4) PRINTED (not handwritten) army lists, one for each of their opponents and one to be turned in at check-in to the judges.
- Players are required to have their rule books handy and to resolve rule disputes between themselves in a fair and friendly manner. However, in the case of ambiguous rules or firm disagreements, there will be Rule Judges circulating on the floor. While we strive for accuracy, it is our main goal to keep games moving along.
- All players are expected to abide by the [AdeptiCon Conduct Policy](#).
- The models used in your army must comply with the [AdeptiCon Model Policy](#) (all models MUST be WYSIWYG and painted to a 3-color minimum standard). If it is not apparent to someone walking by your table what the model represents in the 9th Age world, you are encouraged to label the movement tray. Difficult or confusing model use may result in a penalty to Composition and Sportsmanship.
- If illegal units or rules violations are found in a player's list, at a minimum, the models in violation will be removed from all subsequent play. Tournament points may be deducted and award eligibility may be forfeited.
- AdeptiCon Tournament Judges' rulings are final and arguments or poor conduct by players will not be tolerated. AdeptiCon reserves the right to remove players from the event or AdeptiCon itself with no refunds allowed.

GAMES

- Three games will be played. Scenarios will be used.
- Be sure to set your army out for display after Game 2 for paint judging.
- After filling out each game's scoring sheet, please turn it into the scoring judge.
- Be aware of the Time Restrictions and keep an eye on the Countdown timers. We are striving to have you complete your games. No new turns may begin after the “15 minutes left” mark has been announced.

SCORING

The total number of points available is 125 points, divided up as follows:

Category	Possible Points	% of Total
Battle	75 points	60%
Appearance	25 points	20%
Sportsmanship	15 points	12%
Bonus Points	10 points	8%

++ BATTLE ++

During each game, there are up to 25 total points are up for grabs. 20 of those points are won by achieving victory in the game. Additionally, each player may earn up to 5 Bonus Objective Points per round.

Difference	Win	Loss	Difference	Win	Loss
0-149	10	10	900-1049	16	4
150-299	11	9	1050-1199	17	3
300-449	12	8	1200-1349	18	2
450-599	13	7	1350-1499	19	1
600-749	14	6	1500+	20	0
750-899	15	5			

++ SPORTSMANSHIP ++

Maximum: 15 points. Each Team is expected and required to use the highest level of sportsmanship at all times. At the end of each game, your opponents will rate your Sportsmanship by using a Sportsmanship checklist. Each Yes is worth 1 point.

1. Would you voluntarily play your opponents again? We repeat, the opponents not the list! YES/NO
2. Did your opponents resolve rule disputes in an amicable manner? YES/NO
3. Were both opponents actively involved in the decision making process throughout the game? YES/NO

Best Sportsmanship Voting: After the 3rd game, Teams will choose their favorite opponents from the tournament. This vote is mandatory and will be part of your final results sheet. Each Best Sportsman vote a Team receives is worth two (2) Best Sportsmanship points. A player can earn up to 6 points from Best Sportsmanship votes.

++ BONUS POINTS ++

Thematic Contingents: Teams will receive 5 bonus points for constructing their Team from the groups defined in the Basic Rules section.

Background Story: Teams will receive 5 bonus points for submitting a background story describing how their two armies came together and formed a Team.

AWARDS

- **Best Overall:** This is awarded to the Team that has the highest combine total of the three categories combine (Battle+Sports+Paint).
- **Best General:** Awarded to the Team that had the Highest Battle Points.
- **Best Sports:** Awarded to the Team that had the Highest Sports Score.
- **Best Painted:** All Teams that scored a perfect 25pts on their paint checklist will be considered for this award by our paint judges.

SCHEDULE

SATURDAY, APRIL 2 nd , 2016	
9:00AM - 9:30AM	Check-in and Registration
9:30AM - 12:00PM	Game #1
12:00PM - 12:30PM	Break
12:30PM - 3:00PM	Game #2
3:00PM - 4:30PM	Break and Appearance Judging
4:30PM - 7:00PM	Game #3
7:00PM - 7:30PM	Awards



ADEPTICON 2016

FANTASY BATTLES: THE 9TH AGE TEAM TOURNAMENT

SCENARIO I: DESPERATE TIMES, DESPERATE MEASURES

*** READ THE ENTIRE SCENARIO BEFORE SETTING UP ***

BATTLEFIELD

Before deployment, please check and verify that terrain pieces are in their correct spots using the map on the table card.

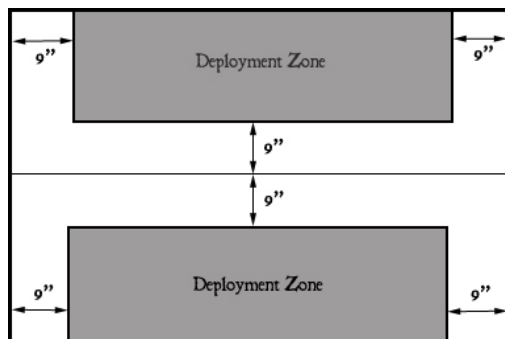

DEPLOYMENT

Teams will roll a die to determine who will deploy first. The winner of the dice roll will determine who will deploy first.

Teams will alternate until they are finish deploying their entire contingents. Teammates will each deploy a unit at the same time. All units with the unit type: Warmachine, must be deployed at the same time. Characters are deployed last.

WHO GOES FIRST

After deployment is completed, each team will roll a die. The team that deploys their entire army first will receive a +1 to their dice result. The winner of the dice roll off will choose who goes first.

GAME LENGTH

The game will last 6 turns or until time is called. Do not start a new round if both Team turns cannot be completed before time expires.



SCENARIO RULES

None.

VICTORY CONDITIONS

Please use the chart to determine the number of Battle Points awarded based on the Victory Point difference.

Difference	Win	Loss
0-149	10	10
150-299	11	9
300-449	12	8
450-599	13	7
600-749	14	6
750-899	15	5
900-1049	16	4
1050-1199	17	3
1200-1349	18	2
1350-1499	19	1
1500+	20	0

Example: Player 1 earns 1787 VP, Player 2 earns 725 VP. The difference is 1062, so player 1 will earn 17 Battle Points while player 2 earns 3 Battle Points.

Conceding: If you concede the game, your opponent will receive the maximum allowed and all of the Objective Points. You will receive a zero for the game and you will not be awarded any Objective Points.

BONUS OBJECTIVE POINTS

Complete the objectives below to earn Bonus Points:

- Destroy or have the Highest Point unit for ONE of the contingents flee off the table.
- Destroy or have BOTH contingent's Highest Point units flee off the table.
- Kill an enemy character (non-captain of a unit).

# of Objectives Completed	Bonus Points
1	1
2	3
3	5



ADEPTICON 2016

FANTASY BATTLES: THE 9TH AGE TEAM TOURNAMENT

SCENARIO 2: DEFENDER OF THE CROWN

*** READ THE ENTIRE SCENARIO BEFORE SETTING UP ***

BATTLEFIELD

Before deployment, please check and verify that terrain pieces are in their correct spots using the map on the table card.

Diagonal: The Table is divided into two halves by a diagonal line across the table. Whoever gets to choose the Deployment Zone decides which diagonal to use. Deployment Zones are areas more than 9" away from this line.

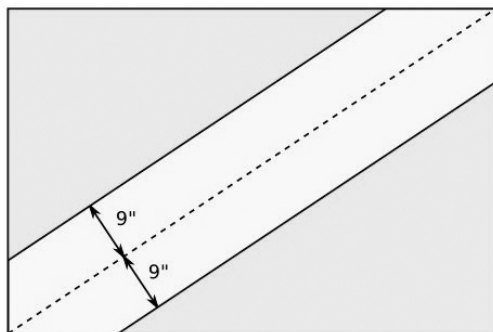

The Flag: Place the Flag provided in the corner of your deployment zone prior to deploying your units. You must place it 6" away from the back & side table edges.

DEPLOYMENT

Follow the deployment phase sequence on pg.16 in the 9th Age Rules Book.

WHO GOES FIRST

Both players must now roll a D6. The player that finished deploying first adds the "Undeployed Units Number" score to their dice roll.

- If the player who finished deploying first gets a higher result, they play first or second as was previously announced.
- If the score is a tie or the player who finished deploying second wins, they can now choose which player has the first turn.

GAME LENGTH

The game will last 6 turns or until time is called. Do not start a new round if both Team turns cannot be completed before time expires.

SCENARIO RULES

Capture the Flag: In order to capture the flag, your unit must be within 3" of the flag.

VICTORY CONDITIONS

Please use the chart to determine the number of Battle Points awarded based on the Victory Point difference.

Difference	Win	Loss
0-149	10	10
150-299	11	9
300-449	12	8
450-599	13	7
600-749	14	6
750-899	15	5
900-1049	16	4
1050-1199	17	3
1200-1349	18	2
1350-1499	19	1
1500+	20	0

Example: Player 1 earns 1787 VP, Player 2 earns 725 VP. The difference is 1062, so player 1 will earn 17 Battle Points while player 2 earns 3 Battle Points.

Conceding: If you concede the game, your opponent will receive the maximum allowed and all of the Objective Points. You will receive a zero for the game and you will not be awarded any Objective Points.

BONUS OBJECTIVE POINTS

Complete the objectives below to earn Bonus Points:

- Capture your opponent's flag.
- Make it through the game without losing your flag.
- Capture more table quarters than your opponent. The table quarters are controlled by the player with the most scoring units (pg.88) wholly within that quarter. Generals will count as (1) pt scoring units in this scenario. If there is a tie, neither player earns the bonus point.

# of Objectives Completed	Bonus Points
1	1
2	3
3	5



ADEPTICON 2016

FANTASY BATTLES: THE 9TH AGE TEAM TOURNAMENT

SCENARIO 3: GRAB WHAT YOU CAN, WHEN YOU CAN

*** READ THE ENTIRE SCENARIO BEFORE SETTING UP ***

BATTLEFIELD

Before deployment, please check and verify that terrain pieces are in their correct spots using the map on the table card.

Classic: The Table is divided into two halves by the straight line through the centre of the board, parallel to the table's long edges. Deployment Zones are areas more than 12" away from this line.

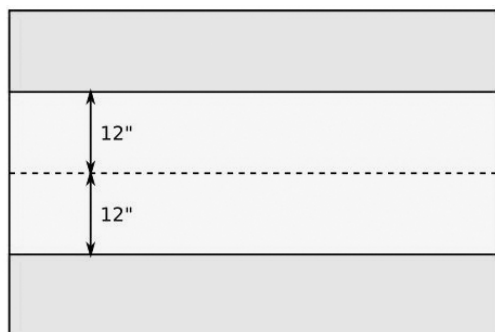

DEPLOYMENT

Follow the deployment phase sequence on pg.16 in the 9th Age Rules Book.

WHO GOES FIRST

Both players must now roll a D6. The player that finished deploying first adds the "Undeployed Units Number" score to their dice roll.

- If the player who finished deploying first gets a higher result, they play first or second as was previously announced.
- If the score is a tie or the player who finished deploying second wins, they can now choose which player has the first turn.

GAME LENGTH

The game will last 6 turns or until time is called. Do not start a new round if both Team turns cannot be completed before time expires.

SCENARIO RULES

The conditions for controlling a piece of terrain are:

- You may use **ANY** of your units.
- Characters do not count as a **UNIT**.
- You must be within 3" of the terrain feature.
- If there is a tie with the number of units within 3" of a terrain piece, the army with the largest unit earns the terrain. If there continues to be a tie, use the 2nd highest scoring unit and continue to work your way down until there is a winner.

VICTORY CONDITIONS

Please use the chart to determine the number of Battle Points awarded based on the Victory Point difference.

Difference	Win	Loss
0-149	10	10
150-299	11	9
300-449	12	8
450-599	13	7
600-749	14	6
750-899	15	5
900-1049	16	4
1050-1199	17	3
1200-1349	18	2
1350-1499	19	1
1500+	20	0

Conceding: If you concede the game, your opponent will receive the maximum allowed and all of the Objective Points. You will receive a zero for the game and you will not be awarded any Objective Points.

BONUS OBJECTIVE POINTS

Complete the objectives below to earn Bonus Points:

- Control more terrain pieces than your opponent.
- Destroy your opponent's most expensive **CORE** unit.
- Keep **BOTH** of your contingent's generals alive for the entire match.

# of Objectives Completed	Bonus Points
1	1
2	3
3	5



ADEPTICON 2016

FANTASY BATTLES: THE 9TH AGE TEAM TOURNAMENT

RESULTS FOR SCENARIO 3: GRAB WHAT YOU CAN, WHEN YOU CAN

YOUR NAME	YOUR ARMY	TABLE #

CIRCLE YOUR RESULT ON THE TABLE BELOW

DIFFERENCE	WIN	LOSS	DIFFERENCE	WIN	LOSS
0-149	10	10	750-899	15	5
150-299	11	9	900-1049	16	4
300-449	12	8	1050-1199	17	3
450-599	13	7	1200-1349	18	2
600-749	14	6	1350-1499	19	1
			1500+	20	0

Bonus Battle Points: (circle one)

0	1	2	3	4	5
---	---	---	---	---	---

TOTAL BATTLE POINTS:

Have your opponents double check your results above.

Have them sign below and acknowledge that the results circled above are accurate and correct.

Opponent's Signature: _____ Army: _____

***** STOP *****

Now, in private, rate the opposing Team's Sportsmanship. Do **NOT** share these results with your opponent.

SPORTSMANSHIP

Yes	No	Question
		Would you voluntarily play your opponents again? We repeat, the opponents not the list!
		Did your opponents resolve rule disputes in an amicable manner?
		Were both opponents actively involved in the decision making process throughout the game?

If you responded **No** to any of the questions above, please state the reasoning for your answer:

BEST SPORTSMANSHIP

Team Name:	
-------------------	--



ADEPTICON 2016

FANTASY BATTLES: THE 9TH AGE TEAM TOURNAMENT

RESULTS FOR SCENARIO 2: DEFENDER OF THE CROWN

TEAM NAME	TEAM ARMIES	TABLE #

CIRCLE YOUR RESULT ON THE TABLE BELOW

DIFFERENCE	WIN	LOSS	DIFFERENCE	WIN	LOSS
0-149	10	10	750-899	15	5
150-299	11	9	900-1049	16	4
300-449	12	8	1050-1199	17	3
450-599	13	7	1200-1349	18	2
600-749	14	6	1350-1499	19	1
			1500+	20	0

Bonus Battle Points: (circle one)

0	1	2	3	4	5
---	---	---	---	---	---

TOTAL BATTLE POINTS:

Have your opponents double check your results above.

Have them sign below and acknowledge that the results circled above are accurate and correct.

Opponent's Signature: _____ Army: _____

***** STOP *****

Now, in private, rate the opposing Team's Sportsmanship. Do **NOT** share these results with your opponent.

SPORTSMANSHIP

Yes	No	Question
		Would you voluntarily play your opponents again? We repeat, the opponents not the list!
		Did your opponents resolve rule disputes in an amicable manner?
		Were both opponents actively involved in the decision making process throughout the game?

If you responded **No** to any of the questions above, please state the reasoning for your answer:

Please turn in this sheet, with your opponents, at the judge's booth after the game.



ADEPTICON 2016

FANTASY BATTLES: THE 9TH AGE TEAM TOURNAMENT

RESULTS FOR SCENARIO I: DESPERATE TIMES, DESPERATE MEASURES

TEAM NAME	TEAM ARMIES	TABLE #

CIRCLE YOUR RESULT ON THE TABLE BELOW

DIFFERENCE	WIN	LOSS	DIFFERENCE	WIN	LOSS
0-149	10	10	750-899	15	5
150-299	11	9	900-1049	16	4
300-449	12	8	1050-1199	17	3
450-599	13	7	1200-1349	18	2
600-749	14	6	1350-1499	19	1
			1500+	20	0

Bonus Battle Points: (circle one)

0	1	2	3	4	5
---	---	---	---	---	---

TOTAL BATTLE POINTS:

Have your opponents double check your results above.

Have them sign below and acknowledge that the results circled above are accurate and correct.

Opponent's Signature: _____ Army: _____

***** STOP *****

Now, in private, rate the opposing Team's Sportsmanship. Do **NOT** share these results with your opponent.

SPORTSMANSHIP

Yes	No	Question
		Would you voluntarily play your opponents again? We repeat, the opponents not the list!
		Did your opponents resolve rule disputes in an amicable manner?
		Were both opponents actively involved in the decision making process throughout the game?

If you responded **No** to any of the questions above, please state the reasoning for your answer:

Please turn in this sheet, with your opponents, at the judge's booth after the game.